

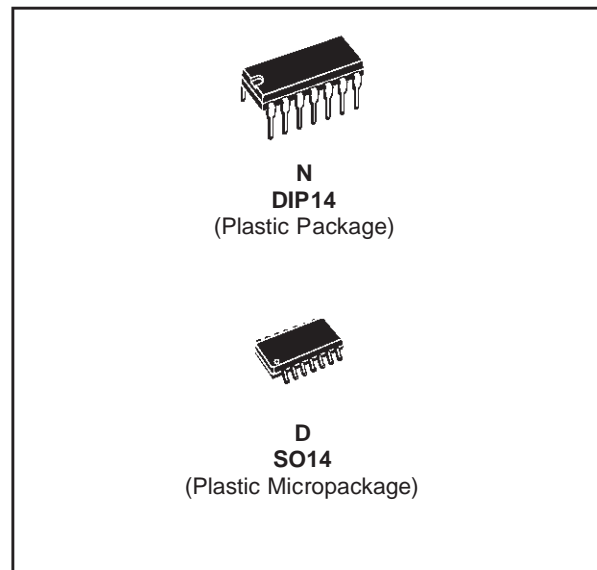

LOW POWER J-FET QUAD OPERATIONAL AMPLIFIERS

- VERY LOW POWER CONSUMPTION : 200µA
- WIDE COMMON-MODE (UP TO V_{CC}^+) AND DIFFERENTIAL VOLTAGE RANGES
- LOW INPUT BIAS AND OFFSET CURRENTS
- OUTPUT SHORT-CIRCUIT PROTECTION
- HIGH INPUT IMPEDANCE J-FET INPUT STAGE
- INTERNAL FREQUENCY COMPENSATION
- LATCH UP FREE OPERATION
- HIGH SLEW RATE : 3.5V/µs



DESCRIPTION

The TL064, TL064A and TL064B are high speed J-FET input quad operational amplifiers. Each of these J-FET input operational amplifiers incorporates well matched, high voltage J-FET and bipolar transistors in a monolithic integrated circuit.

The device features high slew rate, low input bias and offset currents, and low offset voltage temperature coefficient.

ORDER CODE

Part Number	Temperature Range	Package	
		N	D
TL064M/AM/BM	-55°C, +125°C	•	•
TL064I/AI/BI	-40°C, +105°C	•	•
TL064C/AC/BC	0°C, +70°C	•	•

Example : TL064IN

N = Dual in Line Package (DIP)
D = Small Outline Package (SO) - also available in Tape & Reel (DT)

PIN CONNECTIONS (top view)

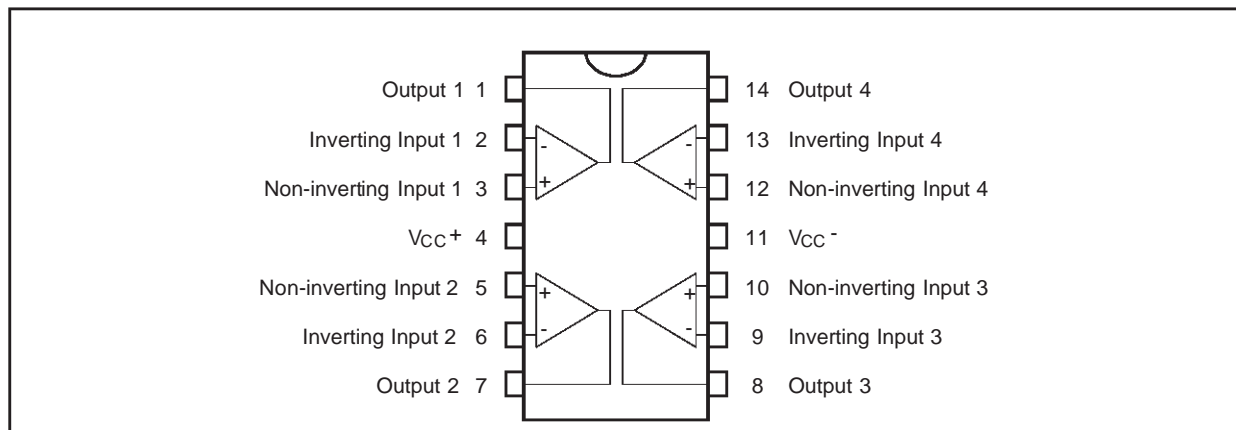

TL064 - TL064A - TL064B

SCHEMATIC DIAGRAM

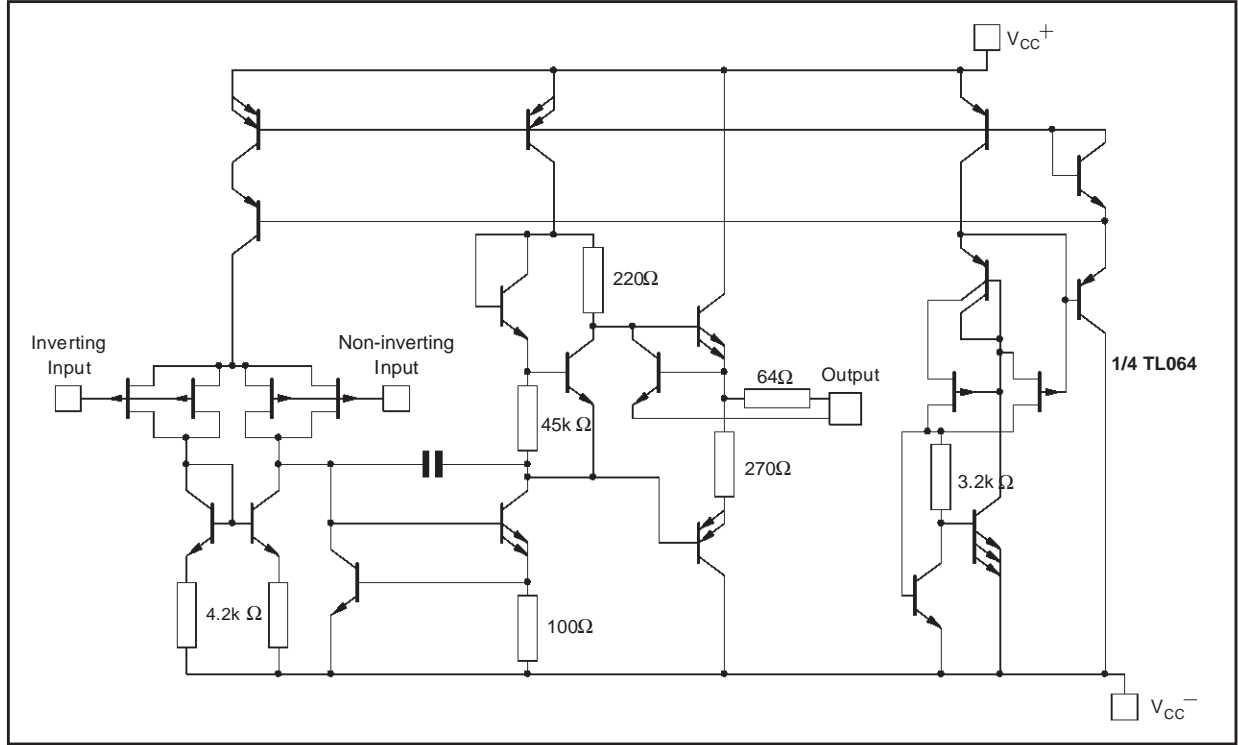

ABSOLUTE MAXIMUM RATINGS

Symbol	Parameter	TL064M, AM, BM	TL064I, AI, BI	TL064C, AC, BC	Unit
V_{CC}	Supply voltage - note 1)	±18			V
V_i	Input Voltage - note 2)	±15			V
V_{id}	Differential Input Voltage - note 3)	±30			V
P_{tot}	Power Dissipation	680			mW
	Output Short-circuit Duration - note 4)	Infinite			
T_{oper}	Operating Free-air Temperature Range	-55 to +125	-40 to +105	0 to +70	°C
T_{stg}	Storage Temperature Range	-65 to +150			°C

1. All voltage values, except differential voltage, are with respect to the zero reference level (ground) of the supply voltages where the zero reference level is the midpoint between V_{CC}^+ and V_{CC}^- .
2. The magnitude of the input voltage must never exceed the magnitude of the supply voltage or 15 volts, whichever is less.
3. Differential voltages are the non-inverting input terminal with respect to the inverting input terminal.
4. The output may be shorted to ground or to either supply. Temperature and/or supply voltages must be limited to ensure that the dissipation rating is not exceeded.

ELECTRICAL CHARACTERISTICS

$V_{CC} = \pm 15V$, $T_{amb} = +25^{\circ}C$ (unless otherwise specified)

Symbol	Parameter	TL064M			TL064I			TL064C			Unit
		Min.	Typ.	Max.	Min.	Typ.	Max.	Min.	Typ.	Max.	
V_{io}	Input Offset Voltage ($R_S = 50\Omega$) $T_{amb} = 25^{\circ}C$ $T_{min} \leq T_{amb} \leq T_{max}$		3	6 15		3	6 9		3	15 20	mV
DV_{io}	Temperature Coefficient of Input Offset Voltage ($R_S = 50\Omega$)		10			10			10		$\mu V/^{\circ}C$
I_{io}	Input Offset Current - note 1) $T_{amb} = 25^{\circ}C$ $T_{min} \leq T_{amb} \leq T_{max}$		5	100 20		5	100 10		5	200 5	pA nA
I_{ib}	Input Bias Current - note 1 $T_{amb} = 25^{\circ}C$ $T_{min} \leq T_{amb} \leq T_{max}$		30	200 50		30	200 20		30	400 10	pA nA
V_{icm}	Input Common Mode Voltage Range	± 11.5	+15 -12		± 11.5	+15 -12		± 11	+15 -12		V
V_{opp}	Output Voltage Swing ($R_L = 10k\Omega$) $T_{amb} = 25^{\circ}C$ $T_{min} \leq T_{amb} \leq T_{max}$	20 20	27		20 20	27		20 20	27		V
A_{vd}	Large Signal Voltage Gain $R_L = 10k\Omega$, $V_o = \pm 10V$, $T_{amb} = 25^{\circ}C$ $T_{min} \leq T_{amb} \leq T_{max}$	4 4	6		4 4	6		3 3	6		V/mV
GBP	Gain Bandwidth Product $T_{amb} = 25^{\circ}C$, $R_L = 10k\Omega$, $C_L = 100pF$		1			1			1		MHz
R_i	Input Resistance		10^{12}			10^{12}			10^{12}		Ω
CMR	Common Mode Rejection Ratio $R_S = 50\Omega$	80	86		80	86		70	76		dB
SVR	Supply Voltage Rejection Ratio $R_S = 50\Omega$	80	95		80	95		70	95		dB
I_{CC}	Supply Current, Per Amplifier $T_{amb} = 25^{\circ}C$, no load, no signal		200	250		200	250		200	250	μA
V_{o1}/V_{o2}	Channel Separation $A_v = 100$, $T_{amb} = 25^{\circ}C$		120			120			120		dB
P_D	Total Power Consumption $T_{amb} = 25^{\circ}C$, no load, no signal		6	7.5		6	7.5		6	7.5	mW
SR	Slew Rate $V_i = 10V$, $R_L = 10k\Omega$, $C_L = 100pF$, $A_v = 1$	1.5	3.5		1.5	3.5		1.5	3.5		V/ μs
t_r	Rise Time 5 (see figure 1) $V_i = 20mV$, $R_L = 10k\Omega$, $C_L = 100pF$, $A_v = 1$		0.2			0.2			0.2		μs
K_{ov}	Overshoot Factor (see figure 1) $V_i = 20mV$, $R_L = 10k\Omega$, $C_L = 100pF$, $A_v = 1$ (see figure 1)		10			10			10		%
e_n	Equivalent Input Noise Voltage $R_S = 100\Omega$, $f = 1KHz$		42			42			42		$\frac{nV}{\sqrt{Hz}}$

1. The input bias currents of a FET-input operational amplifier are normal junction reverse currents, which are temperature sensitive. Pulse techniques must be used that will maintain the junction temperature as close to the ambient temperature as possible.

TL064 - TL064A - TL064B

ELECTRICAL CHARACTERISTICS

$V_{CC} = \pm 15V$, $T_{amb} = +25^{\circ}C$ (unless otherwise specified)

Symbol	Parameter	TL064AC, AI, AM			TL064BC, BI, BM			Unit
		Min.	Typ.	Max.	Min.	Typ.	Max.	
V_{io}	Input Offset Voltage ($R_S = 50\Omega$) $T_{amb} = 25^{\circ}C$ $T_{min} \leq T_{amb} \leq T_{max}$		3	6 7.5		2	3 5	mV
DV_{io}	Temperature Coefficient of Input Offset Voltage ($R_S = 50\Omega$)		10			10		$\mu V/^{\circ}C$
I_{io}	Input Offset Current - note 1) $T_{amb} = 25^{\circ}C$ $T_{min} \leq T_{amb} \leq T_{max}$		5	100 3		5	100 3	pA nA
I_{ib}	Input Bias Current - note 1 $T_{amb} = 25^{\circ}C$ $T_{min} \leq T_{amb} \leq T_{max}$		30	200 7		30	200 7	pA nA
V_{icm}	Input Common Mode Voltage Range	± 11.5	+15 -12		± 11.5	+15 -12		V
V_{opp}	Output Voltage Swing ($R_L = 10k\Omega$) $T_{amb} = 25^{\circ}C$ $T_{min} \leq T_{amb} \leq T_{max}$	20 20	27		20 20	27		V
A_{vd}	Large Signal Voltage Gain $R_L = 10k\Omega$, $V_o = \pm 10V$, $T_{amb} = 25^{\circ}C$ $T_{min} \leq T_{amb} \leq T_{max}$	4 4	6		4 4	6		V/mV
GBP	Gain Bandwidth Product $T_{amb} = 25^{\circ}C$, $R_L = 10k\Omega$, $C_L = 100pF$		1			1		MHz
R_i	Input Resistance		10^{12}			10^{12}		Ω
CMR	Common Mode Rejection Ratio $R_S = 50\Omega$	80	86		80	86		dB
SVR	Supply Voltage Rejection Ratio $R_S = 50\Omega$	80	95		80	95		dB
I_{CC}	Supply Current (Per Amplifier) $T_{amb} = +25^{\circ}C$, no load, no signal		200	250		200	250	μA
V_{o1}/V_{o2}	Channel Separation $A_V = 100$, $T_{amb} = +25^{\circ}C$		120			120		dB
P_D	Total Power Consumption (Each Amplifier) $T_{amb} = 25^{\circ}C$, no load, no signal		6	7.5		6	7.5	mW
SR	Slew Rate $V_i = 10V$, $R_L = 10k\Omega$, $C_L = 100pF$, $A_V = 1$	1.5	3.5		1.5	3.5		V/ μs
t_r	Rise Time $V_i = 20mV$, $R_L = 10k\Omega$, $C_L = 100pF$, $A_V = 1$		0.2			0.2		μs
K_{ov}	Overshoot Factor (see figure 1) $V_i = 20mV$, $R_L = 10k\Omega$, $C_L = 100pF$, $A_V = 1$		10			10		%
e_n	Equivalent Input Noise Voltage $R_S = 100\Omega$, $f = 1KHz$		42			42		$\frac{nV}{\sqrt{Hz}}$

1. The input bias currents of a FET-input operational amplifier are normal junction reverse currents, which are temperature sensitive. Pulse techniques must be used that will maintain the junction temperature as close to the ambient temperature as possible.

MAXIMUM PEAK-TO-PEAK OUTPUT VOLTAGE versus SUPPLY VOLTAGE

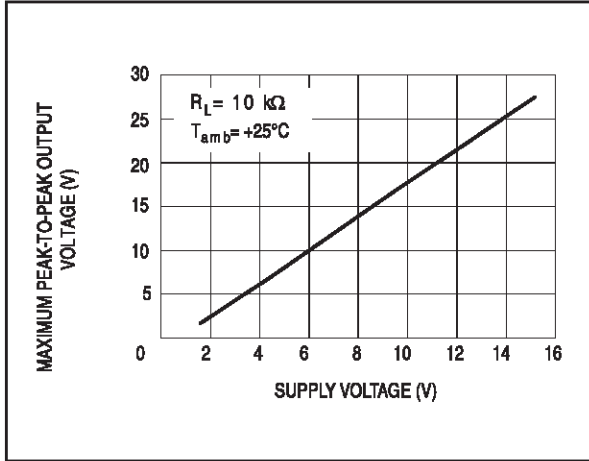

MAXIMUM PEAK-TO-PEAK OUTPUT VOLTAGE versus FREE AIR TEMPERATURE

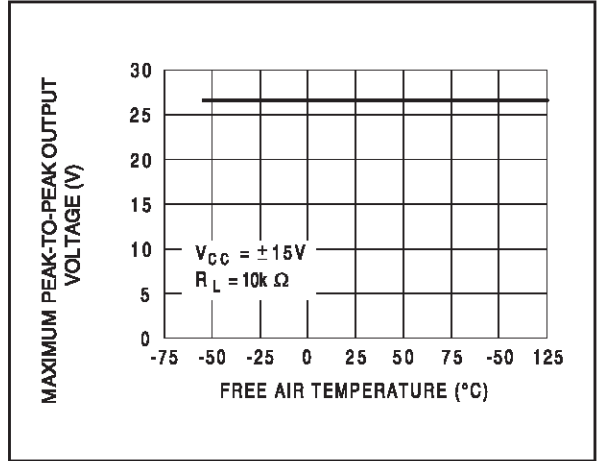

MAXIMUM PEAK-TO-PEAK OUTPUT VOLTAGE versus LOAD RESISTANCE

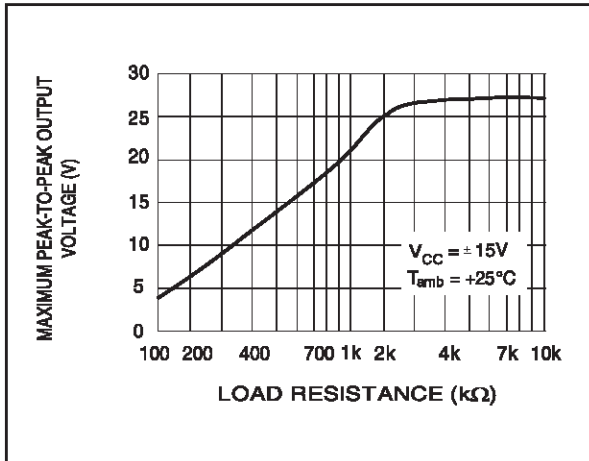

MAXIMUM PEAK-TO-PEAK OUTPUT VOLTAGE versus FREQUENCY

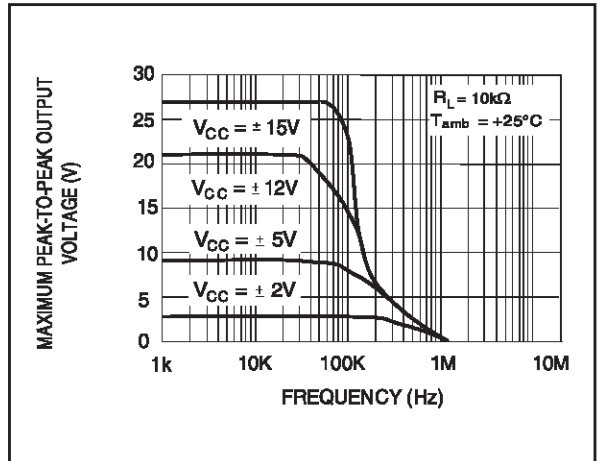

DIFFERENTIAL VOLTAGE AMPLIFICATION versus FREE AIR TEMPERATURE

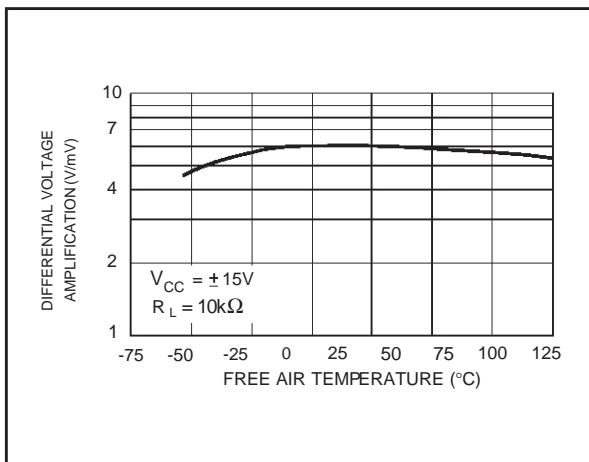

LARGE SIGNAL DIFFERENTIAL VOLTAGE AMPLIFICATION AND PHASE SHIFT versus FREQUENCY

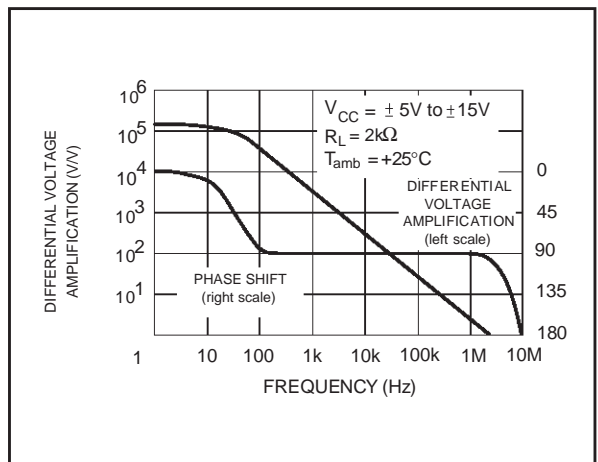

TL064 - TL064A - TL064B

SUPPLY CURRENT PER AMPLIFIER versus SUPPLY VOLTAGE

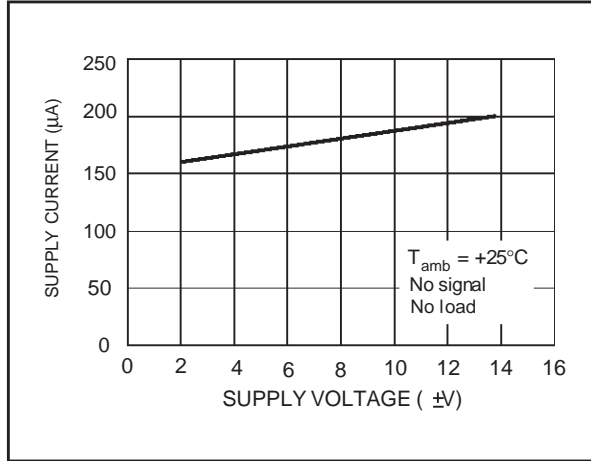

SUPPLY CURRENT PER AMPLIFIER versus FREE AIR TEMPERATURE

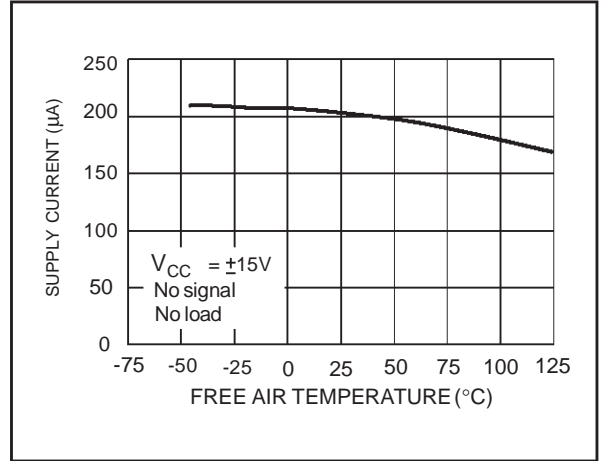

TOTAL POWER DISSIPATED versus FREE AIR TEMPERATURE

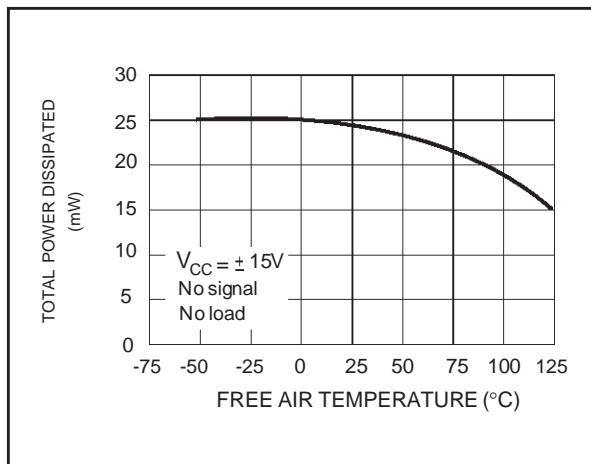

COMMON MODE REJECTION RATIO versus FREE AIR TEMPERATURE

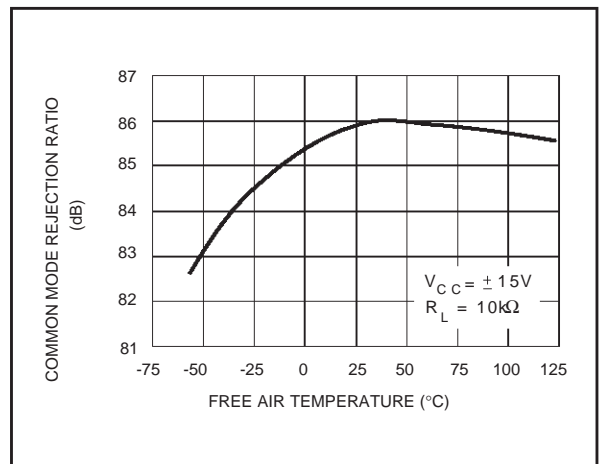

NORMALIZED UNITY GAIN BANDWIDTH, SLEW RATE, AND PHASE SHIFT versus TEMPERATURE

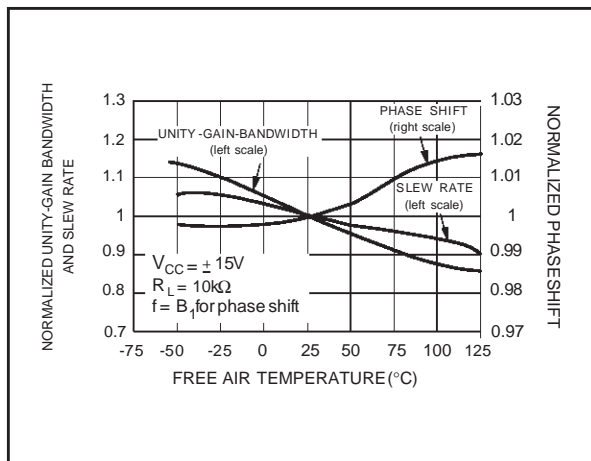

INPUT BIAS CURRENT versus FREE AIR TEMPERATURE

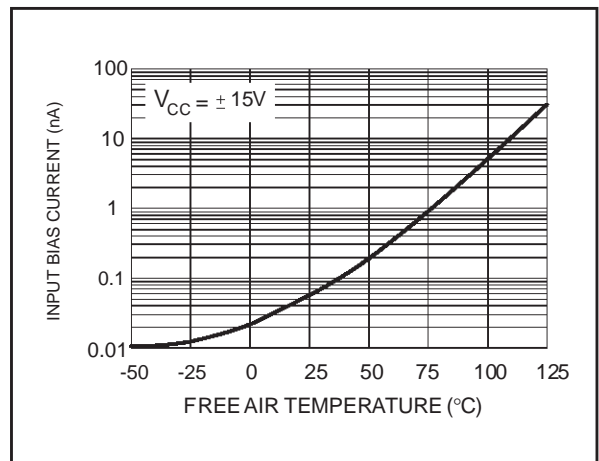

VOLTAGE FOLLOWER LARGE SIGNAL PULSE RESPONSE

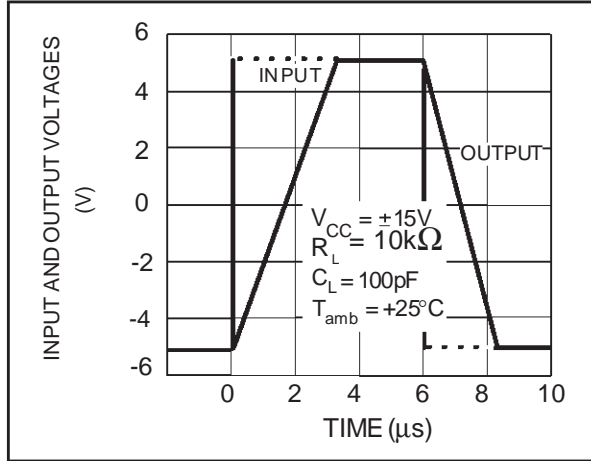

OUTPUT VOLTAGE versus ELAPSED TIME

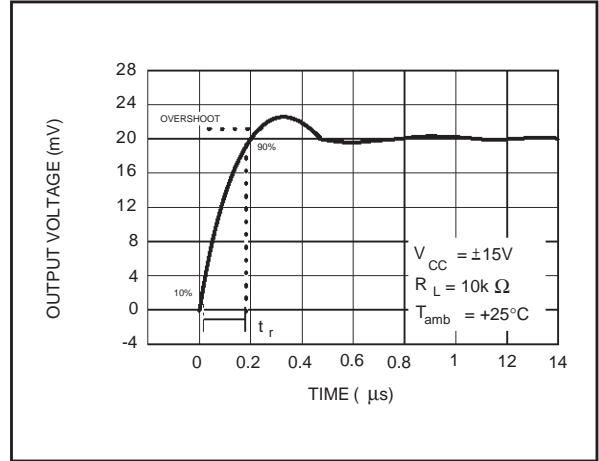

EQUIVALENT INPUT NOISE VOLTAGE versus FREQUENCY

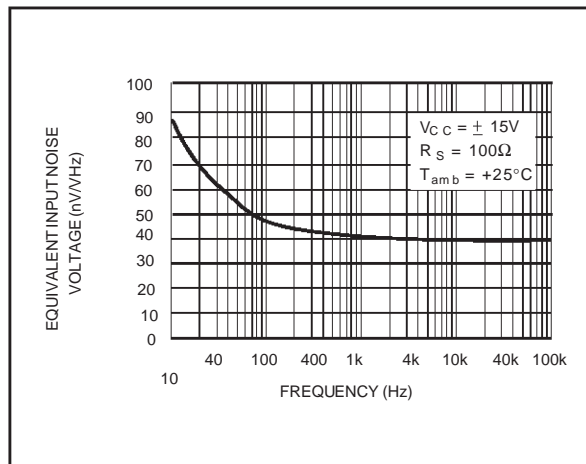

PARAMETER MEASUREMENT INFORMATION

Figure 1 : Voltage Follower

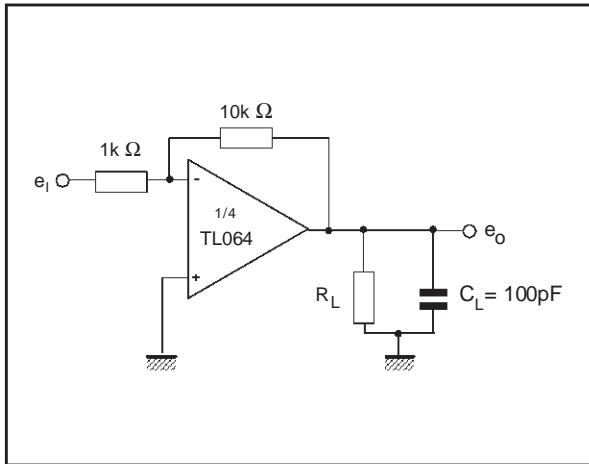
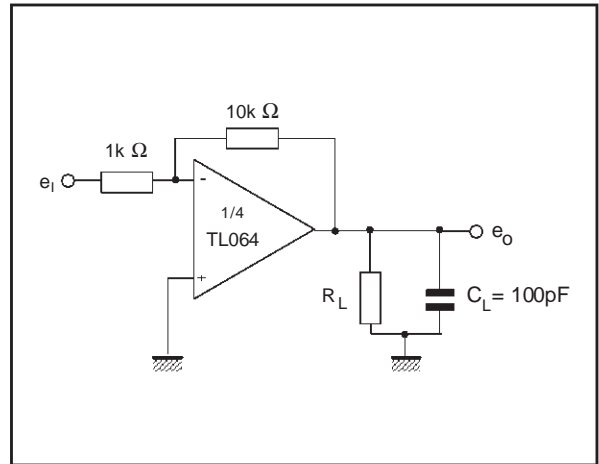
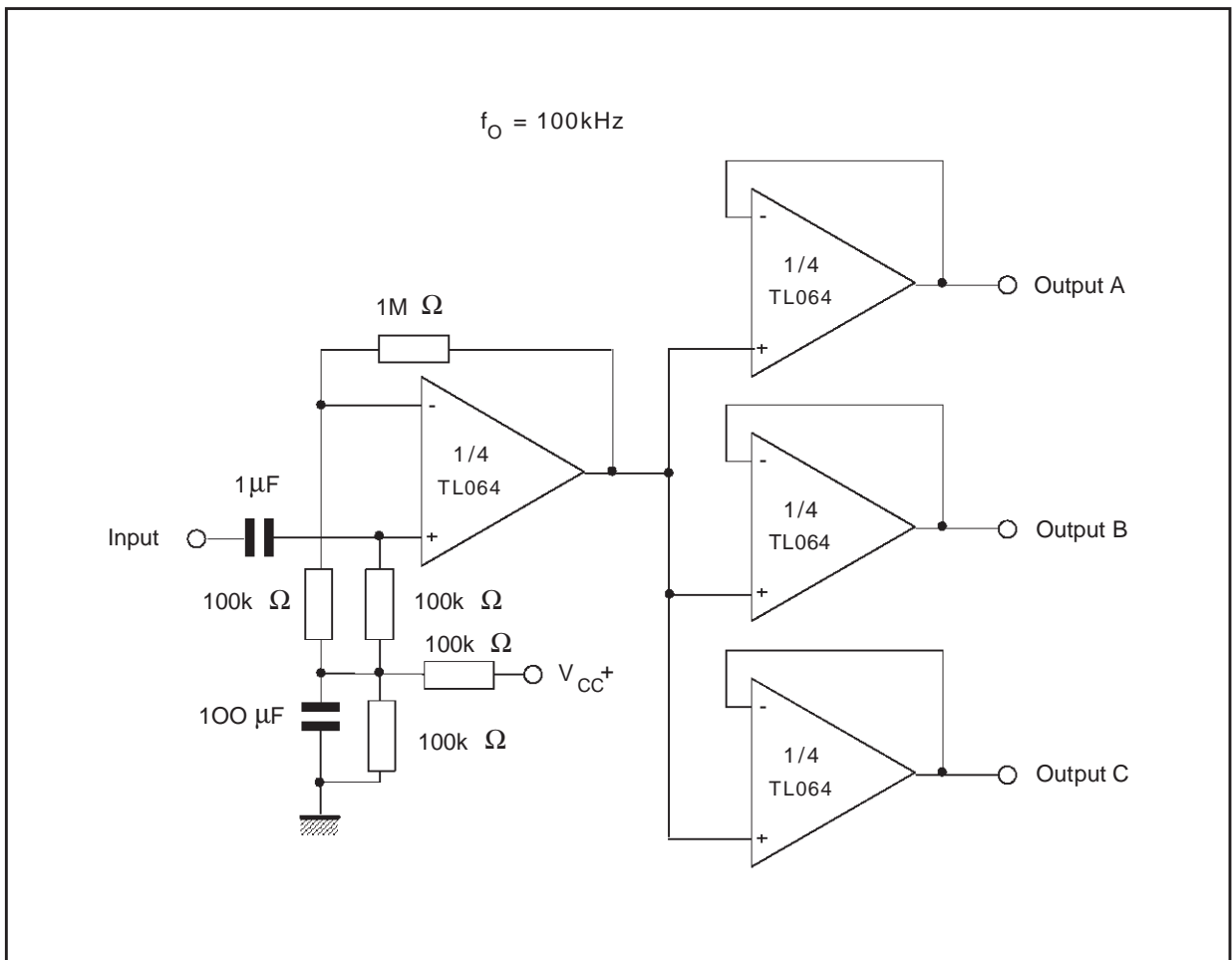

Figure 2 : Gain-of-10 Inverting Amplifier



TYPICAL APPLICATIONS

AUDIO DISTRIBUTOR AMPLIFIER



PACKAGE MECHANICAL DATA
14 PINS - PLASTIC DIP

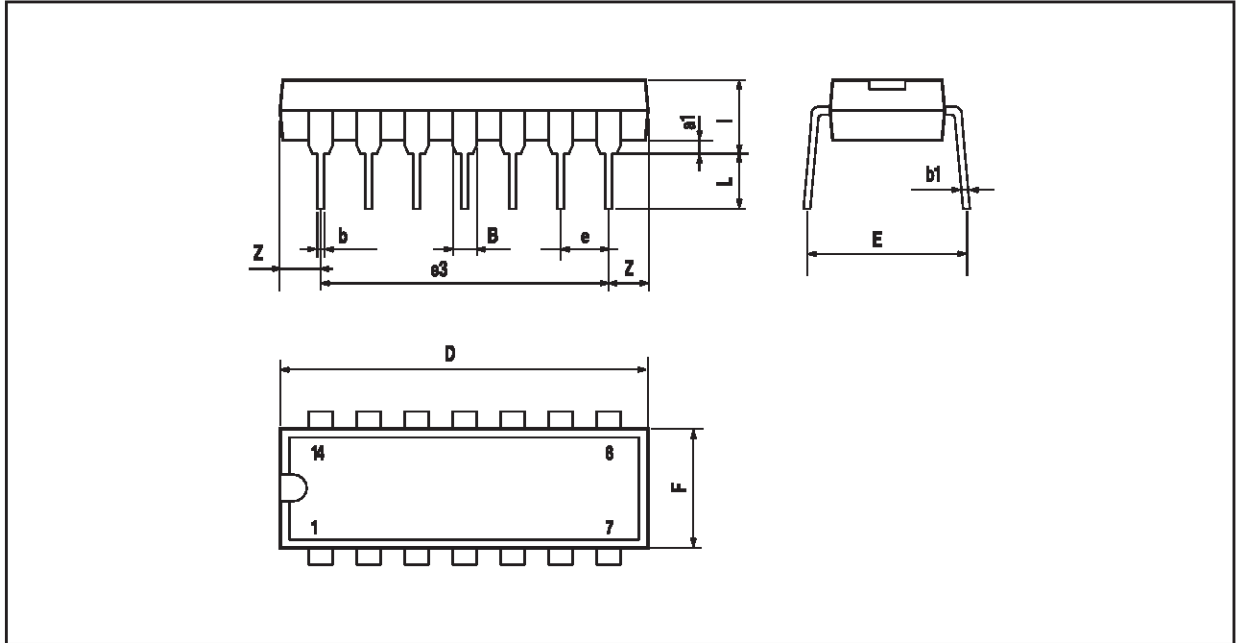

Dimensions	Millimeters			Inches		
	Min.	Typ.	Max.	Min.	Typ.	Max.
a1	0.51			0.020		
B	1.39		1.65	0.055		0.065
b		0.5			0.020	
b1		0.25			0.010	
D			20			0.787
E		8.5			0.335	
e		2.54			0.100	
e3		15.24			0.600	
F			7.1			0.280
i			5.1			0.201
L		3.3			0.130	
Z	1.27		2.54	0.050		0.100

TL064 - TL064A - TL064B

PACKAGE MECHANICAL DATA 14 PINS - PLASTIC MICROPACKAGE (SO)

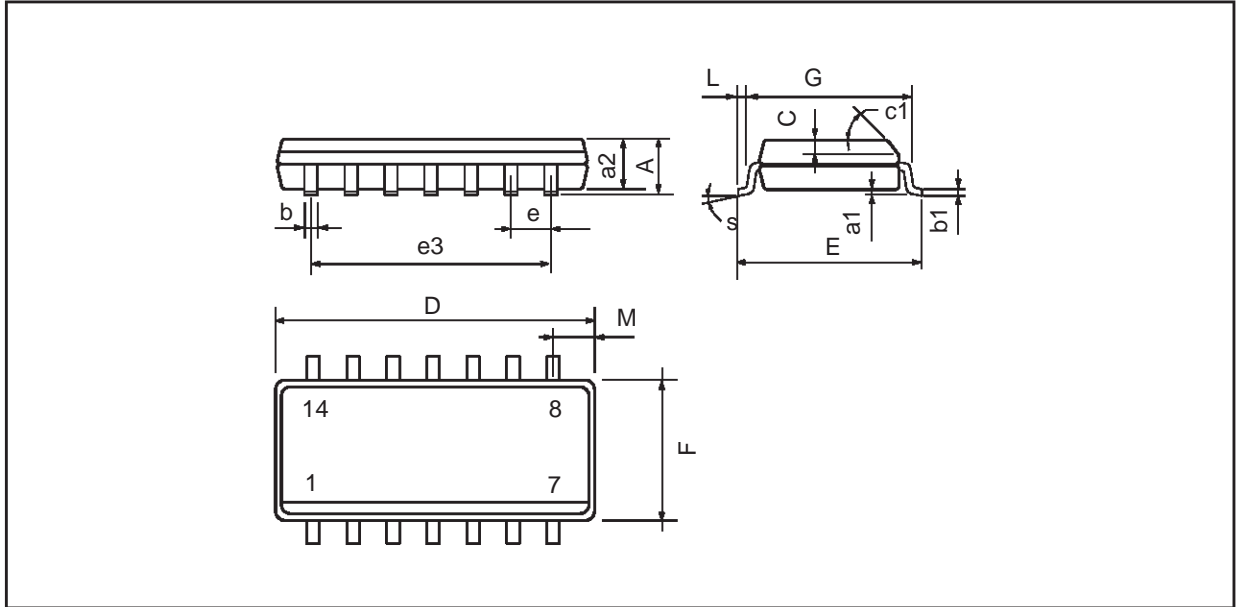

Dimensions	Millimeters			Inches		
	Min.	Typ.	Max.	Min.	Typ.	Max.
A			1.75			0.069
a1	0.1		0.2	0.004		0.008
a2			1.6			0.063
b	0.35		0.46	0.014		0.018
b1	0.19		0.25	0.007		0.010
C		0.5			0.020	
c1	45° (typ.)					
D (1)	8.55		8.75	0.336		0.344
E	5.8		6.2	0.228		0.244
e		1.27			0.050	
e3		7.62			0.300	
F (1)	3.8		4.0	0.150		0.157
G	4.6		5.3	0.181		0.208
L	0.5		1.27	0.020		0.050
M			0.68			0.027
S	8° (max.)					

Note : (1) D and F do not include mold flash or protrusions - Mold flash or protrusions shall not exceed 0.15mm (.066 inc) ONLY FOR DATA BOOK.

Information furnished is believed to be accurate and reliable. However, STMicroelectronics assumes no responsibility for the consequences of use of such information nor for any infringement of patents or other rights of third parties which may result from its use. No license is granted by implication or otherwise under any patent or patent rights of STMicroelectronics. Specifications mentioned in this publication are subject to change without notice. This publication supersedes and replaces all information previously supplied. STMicroelectronics products are not authorized for use as critical components in life support devices or systems without express written approval of STMicroelectronics.

© The ST logo is a registered trademark of STMicroelectronics

© 2001 STMicroelectronics - Printed in Italy - All Rights Reserved
STMicroelectronics GROUP OF COMPANIES

Australia - Brazil - China - Finland - France - Germany - Hong Kong - India - Italy - Japan - Malaysia - Malta - Morocco
Singapore - Spain - Sweden - Switzerland - United Kingdom

© <http://www.st.com>